

Bu Resim MESA OTO ELEKTRİK LTD.ŞTİ'nin malıdır. Şirket Yetkililerinin izni olmaksızın kopya edilemez, üzerinde değişiklik yapılamaz. This image MESA AUTO ELECTRIC LTD.'s are property. Can not be copied without the consent of the company authorized, any changes can be made.

PARÇA KODU PART CODE	PARÇA ADI PART NAME	ERKEK TERMİNAL MALE TERMINAL	a ÖLÇÜSÜ (AYAR) a MEASURE (SET)	s ÖLÇÜSÜ (KALINLIK) s MEASURE (THICKNESS)	Malzeme Material	Kaplama Coating
TD 2112.80 DP	STANDART DIŞI FİŞ B.A.6.3 (0.80) =DP=	0.80	0.55±0.1	0.38±0.05	(CuZn30) Pirinç / Brass	—
TD 2112.80 RP	STANDART DIŞI FİŞ B.A.6.3 (0.80) =RP=	0.80	0.55±0.1	0.38±0.05	(CuZn30) Pirinç / Brass	—
TD 2112.80 RPK	STANDART DIŞI FİŞ B.A.6.3 (0.80) =RPK=	0.80	0.55±0.1	0.38±0.05	(CuZn30) Pirinç / Brass	Kalay / Sn (3-5µ)
TD 2112.80 RPG	STANDART DIŞI FİŞ B.A.6.3 (0.80) =RPG=	0.80	0.55±0.1	0.38±0.05	(CuZn30) Pirinç / Brass	Gümüş / Ag (>1µ)
TD 2112.80 RÇN	STANDART DIŞI FİŞ B.A.6.3 PASLANMAZ (0.80) =RÇN=	0.80	0.65±0.1	0.40±0.05	Nikel kaplı çelik / Nickel plated Steel	Nikel / Ni (≥1.5µ)

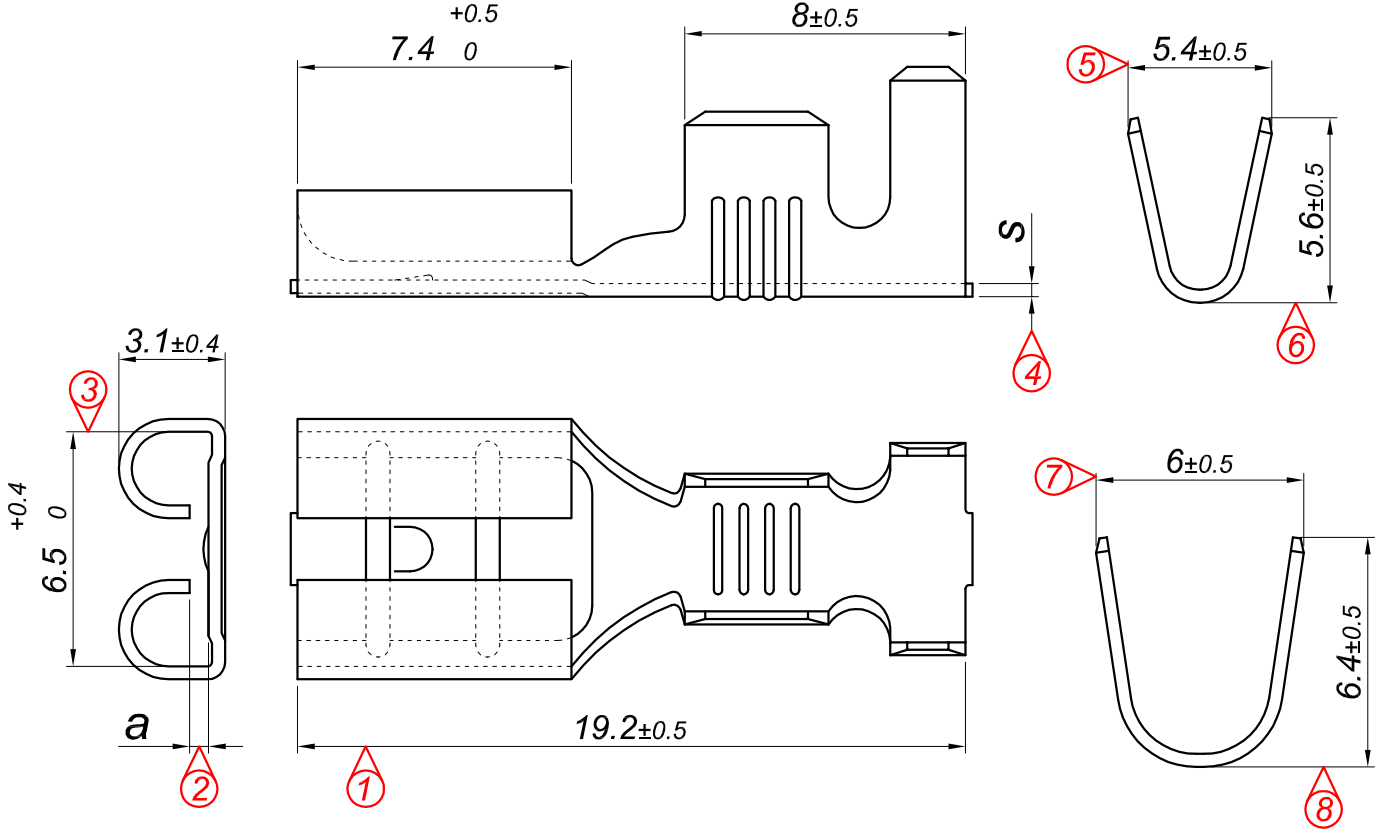

Perspektif
Perspective

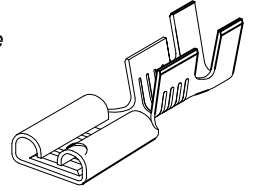

Kalıp çıkış yönü
Mold output direction ← → Makara açılım yönü
Reel opening direction

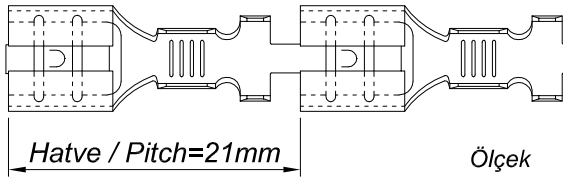

Kablo Kesiti
Wire Section : 2.50 - 6 mm²

Resim üzerinden ölçü almayınız
do not measure on drawing

Tarih / Date	09.06.2011	İmza /Signature	Ölçek /Scale			
Çizen / Desing	M.Yağcı		5 / 1	No		
Onay / Approval	S.Gölcük				Değişiklik / Revision	Tarih/Date
	Parça Adı: Part Name	STANDART DIŞI FİŞ BÜYÜK AYAK 6.3			Parça Kodu: Part Code	TD 2112